

# POWER SLIDING CLAMP

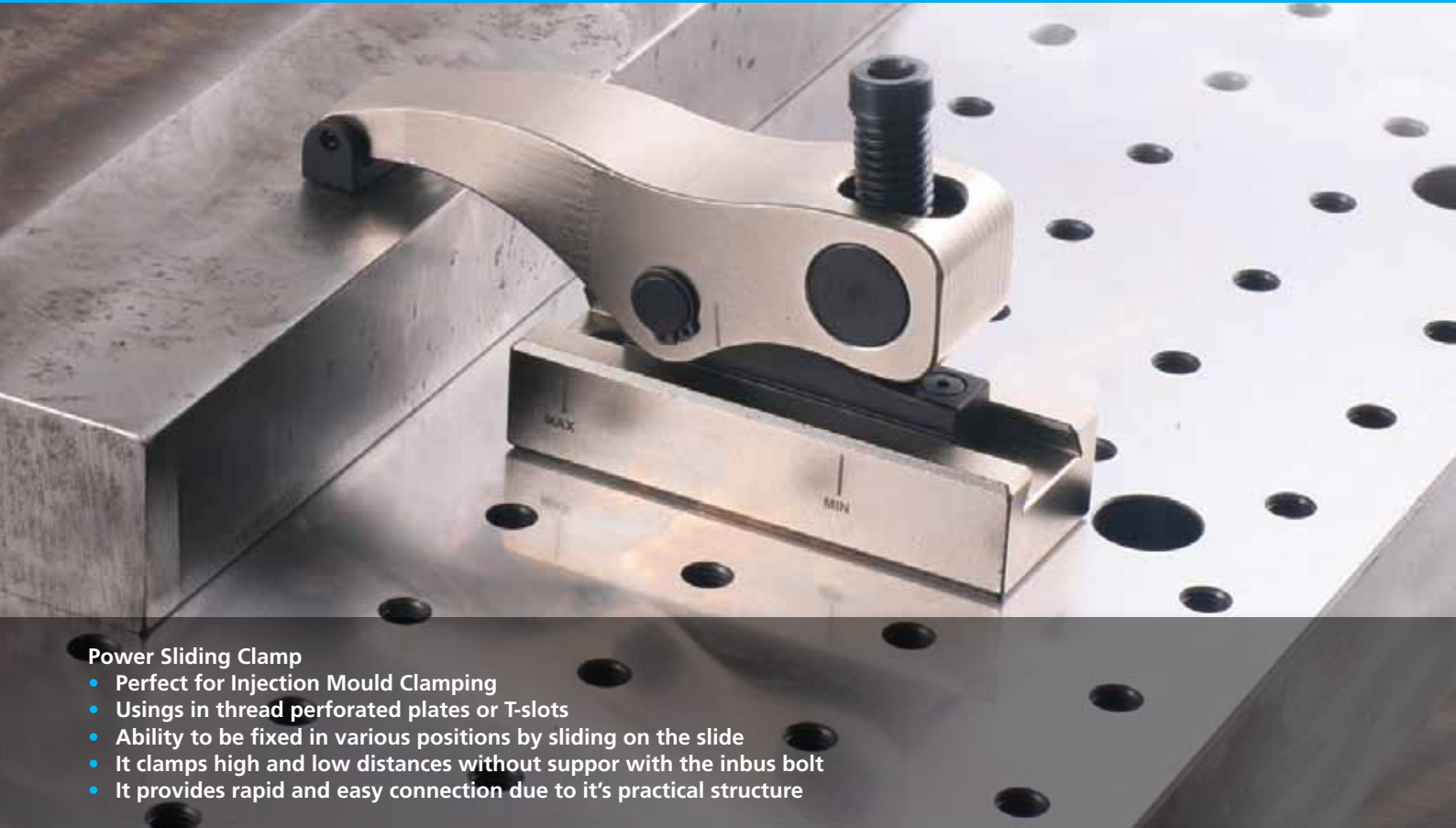

## Power Sliding Clamp

- Perfect for Injection Mould Clamping
- Usings in thread perforated plates or T-slots
- Ability to be fixed in various positions by sliding on the slide
- It clamps high and low distances without support with the inbus bolt
- It provides rapid and easy connection due to it's practical structure

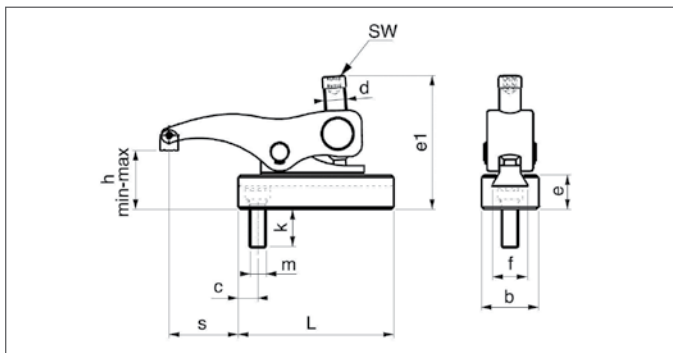

Part No.	Thread	h-Min	h-Max	s	e1	d	sw	L	e	b	c	f	K	Clamping force Kgf
SC-20-12	M12	0	60	15-83	113	M18	10	128	38	48	16	28	22	2000
SC-20-16	M16	0	60	15-83	113	M18	10	128	38	48	16	28	26	2000
SC-25-16	M16	0	62	18-96	125	M20	12	140	42	55	18	32	26	2500
SC-25-18	M18	0	62	18-96	125	M20	12	140	42	55	18	32	30	2500
SC-25-20	M20	0	62	18-96	125	M20	12	140	42	55	18	32	30	2500
SC-25-24	M24	2	64	18-96	142	M20	12	170	45	75	18	35	42	3000