



ATTENTION

START UP TCU-120

Connect the entire electrical and hydraulic system between the user and the user's process.

The minimum pressure of the user's water supply line must be 3 bars.

Turn on the TCU using the main switch.

The user will check or change the working set point, etc.

To start the process, open the water inlet key located on the back of the TCU. Then press the pump on switch.

In the heating phase, the process pressure may reach 6 bars. Once the working temperature has stabilized, the pressure will stabilize at the initial 4 bars.

DISCONNECT TCU-120

To depressurize the process, stop the pump and then close the water inlet valve on the back of the TCU. With the TCU under electrical tension, press the black button located on the front "DRAIN PRESSURE OFF".

Mouldpro ApS
Baltorpbakken 10
2750 Ballerup, Denmark
Tel.: + 45 70 20 31 31
Web: www.mouldpro.com



Manual use and maintenance

Model :

Unit number :

1. GENERAL INFORMATION
2. TRANSPORT, INSTALLATION AND STARTING
3. EQUIPMENT PLACEMENT
4. MAINTENANCE
5. STARTING
6. CIRCUIT FLUID – WATER UNIT
7. CIRCUIT FLUID – OIL UNIT
8. CIRCUIT FLUID - PRESSURIZED WATER UNIT
9. TEMPERATURE SETTING
10. CE STANDARDS
11. HIDRAULIC / ELECTRIC DIAGRAMS
12. OPERATION AND OPTIONS PCB DISPLAYS CARD



1. GENERAL INFORMATION

The instruction manual is part of a pack as technical guidance for the use of the equipment and for the complete functional benefit. It represents both in the context of product liability as indispensable source of information for the user, as well as to preserve from damage. It is also a previous requirement for EC standards and placing the EC mark on the unit.

The manual has been prepared by :

Mouldpro ApS
Baltorpbakken 10
2750 Ballerup, Denmark
Tel.: + 45 70 20 31 31
Web: www.mouldpro.com

In the following pages, the full company name is replaced by the term "manufacturer"

All rights on the unit, manufacturing, added drawings, etc are owned by the manufacturer and are subject to the Law on Copyright and Related Rights (Copyright Act) from 09/09/1965 to the current version.

According to copyright law, competition law and the Civil Code, duplicity is only allowed by written permission prior written permission. Documents can not be used by unauthorized persons and it can not be copied.

1.1 Warranty and liability

For people and / or property damage that may result from non-compliance with rules of this handbook Mouldpro ApS doesn't assume responsibility.

Failure to follow established rules or tips will void the warranty. Warranty doesn't cover.

Mouldpro ApS assumes no liability or guarantee, if original parts are not used

Warranty, liability, damage and personal injury be rendered ineffective by one or more of the following causes:

- Installation, starting operation of the unit with defective safety devices or improperly installed.
- Non-functioning safety or protective devices.
- Failure to follow the instructions given in the operating instructions regarding the installation, operation and maintenance.
- Change in starting conditions of the electrical connection, operating conditions and performance.
- Reconstruction or other changes in the system without prior written permission of Mouldpro ApS.
- Supervision or misuse of the pieces in the installation.
- Inadequate Repairs
- Misuse of the system, ie, the installation is not under use specifications in Chapter 3.1
- Disasters caused by foreign bodies and acts of violence.

The operating instructions shall be treated as confidential internal document, should not be transmitted to third parties, totally or partially reproduced in any way.

This manual may not be copied without the express written permission of Mouldpro ApS either in whole or in part. It may not be reproduced, distributed, modified, transmitted, translated into any language.

Warranty period: 12 months expedition date

Coverage: The warranty covers the replacement of defective components.

Excluded: the shipping costs and / or labor of technical service. Damage caused by transport.

1.2 Security



1.2.1 Introduction

System components are manufactured according to technical specifications and safety rules and safe operation must be manipulated by qualified personnel, or at least instructed to avoid unexpected malfunction.

Dangerous situations can be found like :

- Physical integrity of the user or third parties.
- Damage to equipment or property belonging to the client.

1.2.2 Warning signs

	<p>Risc</p> <p>Non compliance of established rules causes serious injury</p>
	<p>Warning</p> <p>Each person responsible for the installation, operation, maintenance and repair of the system is required to read the operating instructions and the safety instructions.</p>
	<p>Reference</p> <p>Here are some practical tips and other important or useful information. An operator must teach to others as the proper way to safely handle</p>

1.2.3 Purpose of use

The unit is manufactured for use specified in the order or in the documentation provided, for other uses will be considered misuse. In case of injury or property damage, the manufacturer shall not be liable. See Chapter warranty and liability.

The risk is your responsibility

Purpose of use also includes:

Instruction Manual

Compliance with the inspection and maintenance

Check all devices before starting production, in case of anomaly contact with our Customer Service department.

Mouldpro ApS
Baltorpbakken 10
2750 Ballerup, Denmark
Tel.: + 45 70 20 31 31
Web: www.mouldpro.com

	Risc
	In case of malfunction or continued malfunction can cause serious personal injury and equipment damage. <ul style="list-style-type: none">➤ turn off the machine immediately➤ immediately inform the Head of Production

Turn off the engine:

- If unusual sound or smells are detected from the unit
- If uncontrolled movements or vibrations are detected in the unit
- If an unusual temperature increase is observed in the unit
- If an increase in electricity consumption is detected



	Warning
	Modifications and / or improper changes may cause equipment malfunction, and a potential for property damage may also result in personal injury.

It shall ensure by the purchaser periodic inspections.

Standards and national accident prevention regulations and the recognized technical rules for safe and professional work must be apply.

Always observe the local rules and regulations for the disposal of ancillary substances (eg lubricants). A copy of the technical documentation must constantly maintain in a visible place.

Electrical / electronic equipment

	Reference
	<p>Areas / voltage components are characterized by the following warning symbols</p> <p> Warning of electrical voltage</p>

	Warning
	<ul style="list-style-type: none">➤ Work on electrical or electronic components can only be carried out by a qualified electrician in accordance with electrical rules.➤ Defective components may be low voltage on that ground can cause injury.➤ Any defect or breakdown must be communicated to the qualified responsible person, this should repair it immediately, unit must be disconnected.

	Reference
	<p>The following safety rules must be followed when working on electrical components :</p> <ul style="list-style-type: none">➤ Turn off the main switch of the machine➤ Unplug the equipment electrically➤ Verify the absence of voltage in the unit➤ Check for auxiliary equipment should not be connected to the unit <p>The safety instructions and manufacturer's performance must be carried out without restriction</p>

Personnel requirements

The customer is obliged to employ only qualified personnel to meet the requirements of relevant state regulations or other provisions that are equivalent to them, as well as the accident prevention rules adopted by the trade association

The supervisor of the department shall ensure the training of maintenance personnel

Employees are required to strictly observe the provisions of the operating instructions and safety rules

Transport, installation starting and maintenance must be performed by qualified personnel

2. Transport, installation and starting

2.1. Transport

Before shipment or change-location following points should be considered:

- Weight is determined from the technical data provided by the manufacturer. Use appropriate means for loading.
- Protect the unit before packing.
- Fasten the unit on a pallet.

	Risc
	<ul style="list-style-type: none">➤ Suspended loads can fall. Danger of injury!➤ If the load is not performed correctly the equipment may fall. Risk of serious injury!➤ Never go under load➤ Use appropriate loading equipments➤ Use secure transport routes

2.1.1. Notes and protective measures for transport preparation

- Sensitive components to be damaged shall be packed separately.
- Protect the equipment against moisture, dirt, dust etc.
- Fasten the machine to prevent movement during transport.
- Stacking equipment is prohibited

2.1.2. Unpacking

- By removing the packaging, make sure the equipment is not damaged
- The packaging material should be disposed according to environmental laws
- Loosen fastening straps, bolts and mounting screws only when the equipment has been placed in the facility

2.1.3. Check the delivery

- The equipment must be inspected immediately after delivery by the forwarder
- Please check the delivery terms to accept the order

2.1.4. Damage during transport / records

- If damage is detected on the unit or on the packaging it must be informed immediately in consignment note.
- Document the damage with pictures.
- Also inform the manufacturer

2.1.5. Storage before starting

In case the unit is not installed immediately, keep it packed and sheltered.

- Do not leave it outdoors !
- Avoid damage due to corrosion !

2.1.6. Storage after shutdown for a period

- Clean the unit
- Cover the unit

2.2. Installation

	Reference
	Read the manual carefully before unpacking the equipment and prepare the installation

	Warning
	The installation must be carried out only by qualified and trained personnel in compliance with the safety instructions. Each person is responsible for the installation, starting, operation, maintenance and repair of the system. It is required to read the operating and safety instructions

2.2.1. Installation Requirements

- Relative humidity 20% to 80% without condensation
- Maximum slope 5mm / m surface
- Maximum permissible ground irregularity 3mm / m

2.2.2. Mechanical connection

	Risc
	When installing the unit may be the case that such equipment is installed in an area with existing machines. Take special attention to the safety of existing machines and the new machine to be installed. Please lease safety standards of EN ISO 12100-2 (Safety of machinery)

- Remove packaging
- Line up the equipment in relation to other components of the installation
- In case there are fragile components that has been separate, install them now.

2.2.3. Electrical connections

	Warning
	Check voltage and frequency of the line with the unit specifications before connecting the unit.

	Reference
	<p>The following safety rules must be followed when working on electrical components :</p> <ul style="list-style-type: none">➤ Turn off the main switch of the machine➤ Unplug the equipment electrically➤ Verify the absence of voltage in the unit➤ Check for auxiliary equipment should not be connected to the unit <p>The safety instructions and manufacturer's performance must be carried out without restriction</p>

2.3. Starting

	Warning
	<p>The installation must be carried out only by qualified and trained personnel in compliance with the safety instructions.</p> <p>Each person is responsible for the installation, starting, operation, maintenance and repair of the system is required to read the operating and the safety instructions</p>

2.3.1. First testing before starting

- Ensure all tools, materials and other materials are out of the working area.
- Ensure that unauthorized person in the starting process
- Check all safety equipment, emergency stop circuits etc.
- Check the installation, connections etc to make sure they are safe and reliable.

2.3.2. Test Operation

The test operation should be performed to detect possible errors.

Under a test operation it is understood that:

- New unit is on test operation
- Pre –delivery from the manufacturer before delivery to the customer
- Preparing the starting of the unit.

	Warning
	Staff is exposed in the test operation of the machine or installing special higher risk than a normal operation. The increased risk is due to the typically higher stress operator (unexpected problems, time pressure, noise, unfavorable weather conditions, communication problems), mutual vulnerability, as different groups often have to work at the same time and possibly also the lack of technical and ineffective protection devices. In addition, the risk of starting a unit components is not considered and it increases risk of accidents.

For safe operation must be strictly observed:

- Definition of responsibilities
- Identification and assessment of dangers associated with testing
- Selecting and technological protection measures or measures of protection component replacement
- Warning "test run"
- Selection of qualified personnel.

3. Unit placement

According to the Machinery Directive have been fulfilled the following conditions for the placing on the market of a unit, or an auxiliary device :

- Creating an assessment in accordance with risk analysis
- Security that is under Directive 2006/42/EC: 2009
- Manual / technical customer documentation
- EC standards declaration of conformity

	Reference
	Manufacturer supplied auxiliary equipment according to Directive 2006/42/EC. Once the equipment is installed customer must inspect the installation and materials for proper operation. If the customer does not put special interest in materials or installation, responsibility will be at his expenses.

3.1. Structural Changes

Without manufacturer's authorization, no changes or modifications can be made to the equipment. All changes require a written consent of the manufacturer, otherwise the EC declaration of conformity may not be valid.

By replacing faulty components it shall be replaced by original parts with the same electrical data and / or mechanical otherwise the security and good performance can not be assured.

4. Maintenance

4.1. Maintenance

	Warning
	Maintenance and cleaning should always be done with the unit unplugged and by authorized personnel

- Check all bolted connections for tightness
- Check hose connections.
- Check the connectors, cables etc.
- Temperature controller units equipped with magnetic pumps can not be manipulated by people with pacemakers

4.2. Maintenance program

Component	Activity	Interval			
		D	W	M	A
Hoses	check tightness		X		
Pipes	check tightness				X
All hose assemblies	Check leakage		X		
Electrical connections, cables and connectors	Check if they are damaged or well fixed		X		
Condition of the unit	Re-tighten / check			X	

5. Starting

5.1. Dismantling



Warning

This work can only be carried out when the unit is unplugged and only by authorized personnel.

- Turn off the main switch of the machine
- Unplugged the unit electrically
- Verify the absence of voltage on the unit
- Check for auxiliary equipment connected to the unit
- Check system pressure. Depressurize the equipment (only teams WDC / WIC) models.



Warning

- Work on electrical or electronic components can only be carried out by a qualified electrician in accordance with electrical rules
- Electrical components can be disconnected under voltage even on that ground can cause injury

5.1.2 Note about installation dismantling

The arrangement of the different materials will be in accordance to compliance, regulations or national laws

Do not mix materials. Disposal must be carried out according to relevant national laws or regulations



Reference

Please read the information in the safety data sheets from manufacturer

Disposal



Problematic substances such as lubricants / oils should not be thrown in the trash or wastewater



Before removing the unit be completely sure to select each of the materials and dismantling according to existing laws.

The management personnel must be properly trained and authorized for this activity. Be complied with all regulations and laws on security

II Notes about this document

- This document is explicitly written out with a version number. Valid only the highest version number. Where reference is made to this document, provided the version number or the date of the document must be specified with (see index)
- This document only describes the controls and display. For more information on individual subcomponents or the entire function ask for the manufacturer.

6. CIRCUIT FLUID / WATER UNIT (open tank)

	<p>Risc</p> <p>Non compliance of established rules causes serious injury</p>
	<p>Warning</p> <p>Each person responsible for the installation, starting, operation, maintenance and repair of the system is required to read the operating instructions and the safety instructions</p>
	<p>Reference</p> <p>Here are some practical tips and other important or useful information. An operator must teach to others as the proper way to safely handle</p>

6.1 Information

Unit can not operate above the boiling point of water.

Unit fills automatically with water by means of a solenoid valve connected to a level sensor in the tank.

Tank is insulated. It has heating elements, the magnetic sensor control water level, temperature sensor and the pump impeller.

Temperature control is achieved by heating the water in the tank, pumping and cooling it to achieve tolerance in the temperature control.

Cooling is accomplished indirectly by circulating cold water through the plate heat exchanger

6.2 INSTALLATION – WATER UNIT

6.2.1 Connecting and filled with water.



- Place the unit as close as possible to temper process
- Connect inlet and outlet of the cooling water in the pipes of the equipment located in the back panel. Use appropriate hoses (see wiring diagram on the back panel).
- Connect the hoses in and out of process equipment to the pipes located on the back panel. Use appropriate working temperature and pressure hoses as indicated:
For units up to 90 - minimum range of hose = 100 ° C and 6 bar
- Check plumbing work to prevent problems
- Connect the equipment to the power supply (check back panel) by a suitable plug for the voltage range and ground
- If external taps have been placed, open them to allow water entry. Make sure all connections are open.
- Rotation of the pump is clockwise, viewed from above through the engine fan. If the pump rotates in the opposite direction, reverse the connections of two phases.



Warning

It is important to ensure there's a differential in the general line of installation. This differential must be sized according to the power of the unit. This can be easily identified on the rating plate located on the back panel of the unit.

7. CIRCUIT FLUID / OIL UNIT (open tank)

	<p>Risc</p> <p>Non compliance of established rules causes serious injury</p>
	<p>Warning</p> <p>Each person responsible for the installation, operation, maintenance and repair of the system is required to read the operating instructions and the safety instructions</p>
	<p>Reference</p> <p>Here are some practical tips and other important or useful information. An operator must teach to others as the proper way to safely handle</p>

7.1 Information

Working temperature varies depending on the unit

The unit is filled manually by a cap on the back panel of the unit.

The tank is insulated. It has heating elements, cooling coil, temperature probe and pump impeller.

The temperature control is achieved by heating the fluid in the tank, pumping and cooling it to achieve tolerance in the temperature control.

Indirectly cooling is achieved by circulating cold water through the coil submerged in the tank fluid

7.2 INSTALLATION – OIL UNIT

7.2.1 Connexion and filled with oil.

- Place the unit as close as possible to temper process
- Connect inlet and outlet of the cooling water in the pipes of the equipment located in the back panel. Use appropriate hoses (see wiring diagram on the back panel).
- Connect the hoses in and out of process equipment to the pipes located on the back panel. Use appropriate working temperature and pressure hoses as indicated:

For units up to 150 / 200°C – minimum range of hose = 210°C and 6 bares

For units up to 250°C – minimum range of hose = 300°C y 10 bares

- Check plumbing work to prevent problems
- The oil fill is done manually from the rear with particular attention to low-level red light oil on the frontal panel of the unit. Fill until the red LED switch off .
- Connect the equipment to the power supply (check back panel) by a suitable plug for the voltage range and ground.
- If external taps have been placed, open them to allow water entry. Make sure all connections are open.
- Rotation of the pump is clockwise, viewed from above through the engine fan. If the pump rotates in the opposite direction, reverse the connections of two phases.

Notes in oil units



- Never leave open containers of oil as they may catch moisture
- If there are bubbles reaching 100 ° C it means that there's water or moisture in the oil, if so, empty the tank and refill with new oil.
- Fill the unit until the red LED on the frontal panel switch off, if filled above the pre-set level the danger of overflow oil runs along the top of the tank. Note that the oil increases in volume when heated
- Always use synthetic thermal oil.



Warning

It is important to ensure there's a differential in the general line of installation. This differential must be sized according to the power of the unit. This can be easily identified on the rating plate located on the back panel of the unit.

8. CIRCUIT FLUID / WATER UNIT PRESSURIZED

	<p>Risc</p> <p>Non compliance of established rules causes serious injury</p>
	<p>Warning</p> <p>Each person responsible for the installation, operation, maintenance and repair of the system is required to read the operating and the safety instructions</p>
	<p>Reference</p> <p>Here are some practical tips and other important or useful information. An operator must teach to others as the proper way to safely handle</p>

8.1 SPECIAL ATTENTION

It is important to purge or empty the unit before disconnecting hoses process, please press drain button located in the frontal panel.

In the model WDC equipment high pressure water inlet shall be 4 bars.

	<p>Warning</p> <p>The installation must be carried out only by qualified and trained personnel in compliance with the safety instructions. Each person is responsible for the installation, starting, operation, maintenance and repair of the system is required to read the operating and the safety instructions</p>
---	--

8.2 Connecting and filled with water

- Place the unit as close as possible to temper process
- Connect inlet and outlet of the cooling water in the pipes of the equipment located in the back panel. Use appropriate hoses (see wiring diagram on the back panel).
- Connect the hoses in and out of process equipment to the pipes located on the back panel. Use appropriate working temperature and pressure hoses as indicated
 - For units up to 140 / 150°C – minimum hose range = 200°C and 10 bares**
 - For units up to 160 / 180°C – minimum hose range = 250°C and 16 bares.**
- Check plumbing work to prevent problems
- Connect the equipment to the power supply (check back panel) by a suitable plug for the voltage range and ground
- If external taps have been placed, open them to allow water entry. Make sure all connections are open.
- Rotation of the pump is clockwise, viewed from above through the engine fan. If the pump rotates in the opposite direction, reverse the connections of two phases.

Special attention in TCU models

It's important to press several times in small intervals drain button located in the frontal panel during three or four first minutes of starting process in order to be sure that air from installation and hoses is drained.



Warning

It is important to ensure there's a differential in the general line of installation. This differential must be sized according to the power of the unit. This can be easily identified on the rating plate located on the back panel of the unit.

9. TEMPERATURE SETTING

9.1 Information

Settings in this PCB card is done via parameters called SET's divided into groups on the front of the circuit have a higher display and lower values indicating the situation in which we find ourselves, we also have 4 keys ↵ < ▲ ▼ that allow us to act on the circuit.

↵ Enter key.

< Key to move from one digit to another.

▲ key to increase values.

▼ key to decrease values.

In normal working situation the upper display indicates the temperature at which the fluid is in and the lower display we have the temperature set we have selected. To change the setpoint press the < key and the lower display will blink then we can change the value using the ▲ ▼ keys to validate the selected value press the key ↵ in the lower display can we jump from units, tens, hundreds and thousands by the < key.

In SET's programming press simultaneously keys ↵ < for 4 or 25 seconds depending on the selected value in the parameter in the SET6 LEVF.

In SET's menu, pass from one to another with the < key and enter in ↵ you want.

Once inside the selected SET pass a parameter to another with ▼ ▲ remember that once we have varied the value must press keys ↵ to validate the change

After 10 seconds without acting on the keyboard and the machine returns to the initial position.

If you have activated the flow function, you can see the fluid flow by pressing the ▼ key and in the lower display appears letter **F** and you visualize the flow value.

If you activate the outlet temperature function, you can see that temperature by pressing the button on the lower ▲ display the letter **t** appear in the lower display value we measured by the thermocouple installed in the external circuit.

To activate the autotuning press ▲ ▼ keys simultaneously and for more than 5 seconds letter **A** appears in bottom display while activated.

9.2 DESCRIPTION AND PARAMETERS LIST

SET 0

- PB** Proportional value of the PID of the process heat
- Ti** Value of the integration time of the PID of the process heat
- td** Value of the derivation time of the PID of the process heat
- re.ty** Relay type that we will use to act on the process (electromechanical relay or SSR)
- Br** Brake heat (parameter to adjust the control)
- Cli** Heat ramp (parameter to adjust the inertia)

SET 1

- CL.pb** Proportional value of the cold process
- CL.br** Cold brake (to adjust the control parameter)
- CL.CL** Cold ramp (parameter to adjust the inertia)

SET 2

- In.Sr** Type of temperature thermocouple in the machine tC1 Pt1 (thermocouple J) (Pt-100 thermocouple).
- VA.ti** Valve open time before alarm
- VA.ty** Mode of operation of the water inlet valve dir (direct) rEv (reverse)
- FL.AC** Activation flowmeter **Off** (disabled) **On** (enabled)
- FL.SC** Signal Type **Src.A** flowmeter (4-20mA) **Src.v** (0-10VDC)
- FL.FS** Limit full scale flow rate (max. 90 l / min)
- FL.LL** Lower limit of the scale of the flow (l / min)
- FL.AL** Alarm flowmeter
- VI.AC** Enabling temperature sensor 2 **Off / On** (installed in the external circuit)
- VI.Sr** Type **tC2** outlet temperature sensor (thermocouple J) **Pt2** (Pt-100)

SET 3

- AL.ty** Temperature type alarm **rEl (relative) GAP (lower and upper both) AbS (absolute)**
- SP.AL** Temperature alarm setpoint
- Al.d** Type of temperature alarm relais operation **dir** (Direct) **rEv** (reverse)
- Sr.AC** Enabling remote setpoint (**Off/On**)
- Sr.SC** Input signal type of the remote setpoint **Src.A** (4-20mA) **Src.v** (0-10vcc)
- Sr.FS** Full scale limit remote setpoint ° C / ° F
- Sr.LL** Minimum scale limit remote setpoint ° C / ° F
- Sr.HL** Maximum limit of the remote setpoint ° C / ° F
- Out.t** Output signal type temperature transmission **Out.A** (4-20mA) **Out.v** (0-10vcc)

SET 4

- BIAS** Correction value indicating the temperature reading ° C / ° F
- unit** Unit of temperature measurement ° C (Celsius) ° F (degrees Fahrenheit)
- SP.LL** Minimum scale limit setpoint ° C / ° F
- SP.HL** Maximum scale limit setpoint
- ti.AC** Enabling timing function (output relay time adjustment) **Off/On**
- ti.ti** Timeline for the timer function (value in minutes)
- Pr.AC** Enabling pressurized function (output relay for this function) **Off/On**
- Pr.AL** Value of the pressurization (80)

SET 5

- deF** In this parameter if you enter the value 100 resets the device to factory settings and entering the value 1562 to monitor and change the SET, s 0 and 1

SET 6

- LEvF** Keyboard Protection 0 = 4 seconds by holding down the keys to enter parameters
1 = 15 seconds

SET 7

COMS Communications interface activation **On / Off**

Addr Address assigned to the circuit

bAud Transmission speed 0-1-2 **0 = 2400, 1 = 4800, 2 = 9600**

PAr Parity bit **0-1-2**

dEn TCU unit working with interface 4-20mAmp

must put value "1" If customer work with one TCU unit but if customer works with several TCU units all TCU units must be set with value "0" less the last one it must be set with value "1"

TCU unit working with interface RS 485

must put value "1" in all TCU units.

SET 8

In.LE Selection level detection **buOy** magnetic sensor **ELEC** electrode.

dC.ti Pump connection time when we reach the optimum water level.

CO.ti Disconnection pump time for low water level.

iP.AC Activation view of process pressure transmitter. **On/Off**

iP.AL Maximum value alarm inlet pressure.

iP.LL Viewing minimum scale inlet pressure.

iP.FS Viewing background scale inlet pressure.

rP.AC Activation pressure transmitter for the regulation process

rP.AL Alarm pressure. Maintain pressure in the process.

rP.LL Minimum pressure level scale process.

rP.FS Background process pressure scale.

9.3 ALARM LIST

9.3.1 In visual display

Err on the lower display = flow alarm (no flow) or open external thermocouple .

Ouer the lower alarm display = open thermocouple

HEAt at the lower temperature alarm display = (depends on how we have programmed)

Red led pump off frontal panel pump thermal protection (pump stop)

Red Led Fluid Level frontal panel Lack of fluid pressure if it is pressurized equipment.

9.3.2 If the unit is equipped with audible / visual alarm

The general alarm relay operates in any of these circumstances

- Thermal pump protection
- Thermocouple open
- Temperature Alarm
- No Flow Alarm
- Exceeding the set time water filling

ALARMS.**St. time**

Maximum process start time. User adjustable. Re-start TCU unit.

FLOU doun

Minimum flow return alarm. User adjustable. Disables heating.

FLOU br.

Connection between flow sensor and PCB card STD/FULL is broken. Disables heating.

P.1 br.

Connection between pump pressure transducer and FULL PCB card is broken.

P.2 br.

Connection between return pressure transducer and FULL PCB card is broken.

rSP Err.

Connection between external signal 4..20mA or 0-10Vdc in order to work with remote set point and PCB card STD/FULL is broken. It holds last setpoint

COMM Err.

No communication RS485 or 0..20mA.

It holds last setpoint

TEMP br.1

Thermocouple broken.

Disables heating and pump. Restarts leak monitoring

PUMP FAIL

Pump protection.

Disables heating and pump. Restarts leak monitoring

P.MAX

Maximum pump pressure. User adjustable.

Disables heating and pump. Restarts leak monitoring

tEMP MAX

Higher degrees deviation to the setpoint. User adjustable.

tEMP Mar.

Upper and lower deviation in degrees from the setpoint. User adjustable.

LEAK

Possible water leak in the process. Disables heating and pump

Re-start TCU unit.

U. L.

Level loss more than 10 seconds continuously in TCU unit tank. Disables heating and pump. Re-start TCU unit.

ALARMS VALIDATION SHOULD BE DONE PUSHING KEY



If the alarm condition persists, one minute after to confirm will show again in the display

MOULDPRO®

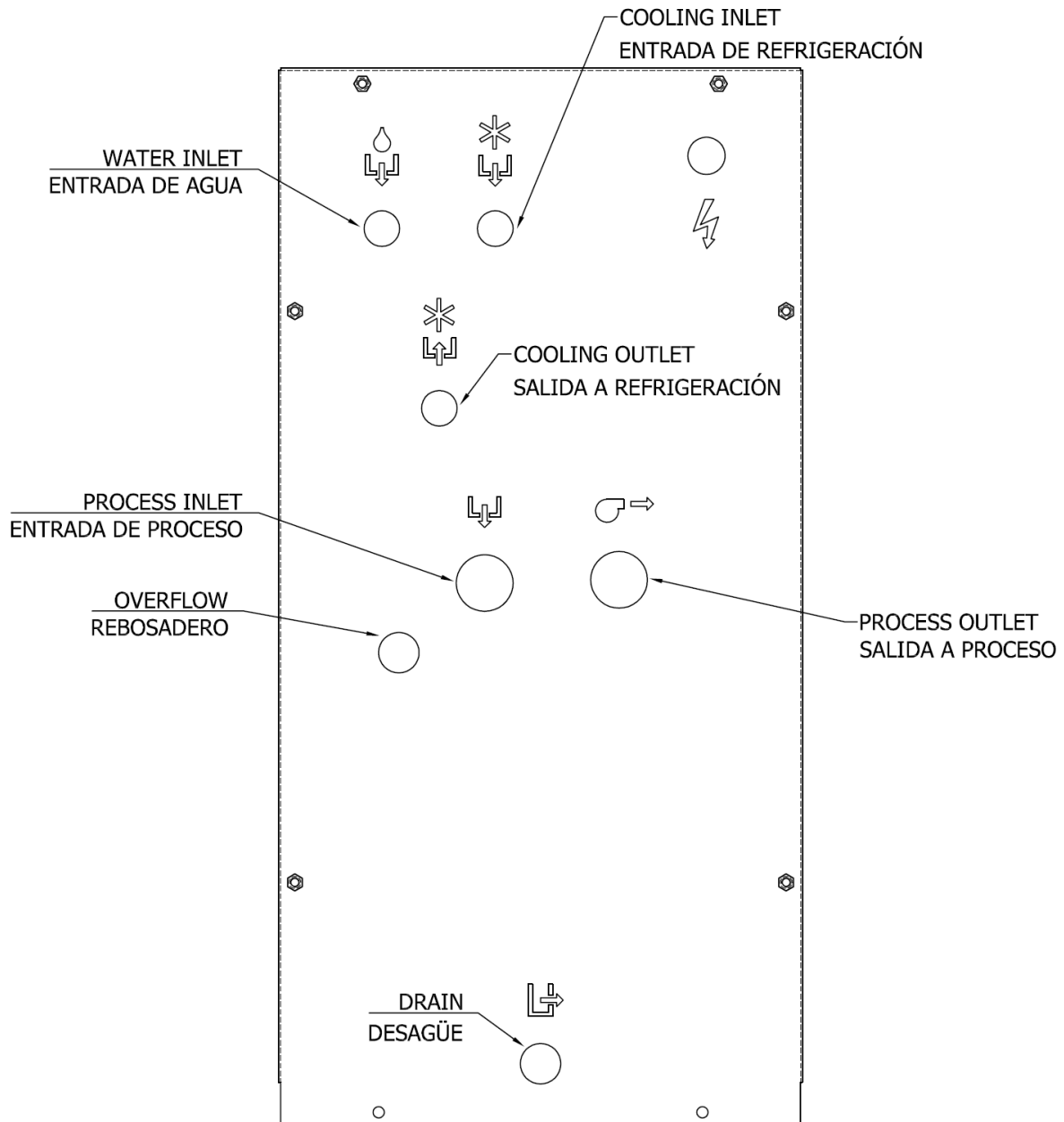

10. DIAGRAMS

11.1 Electronic circuit

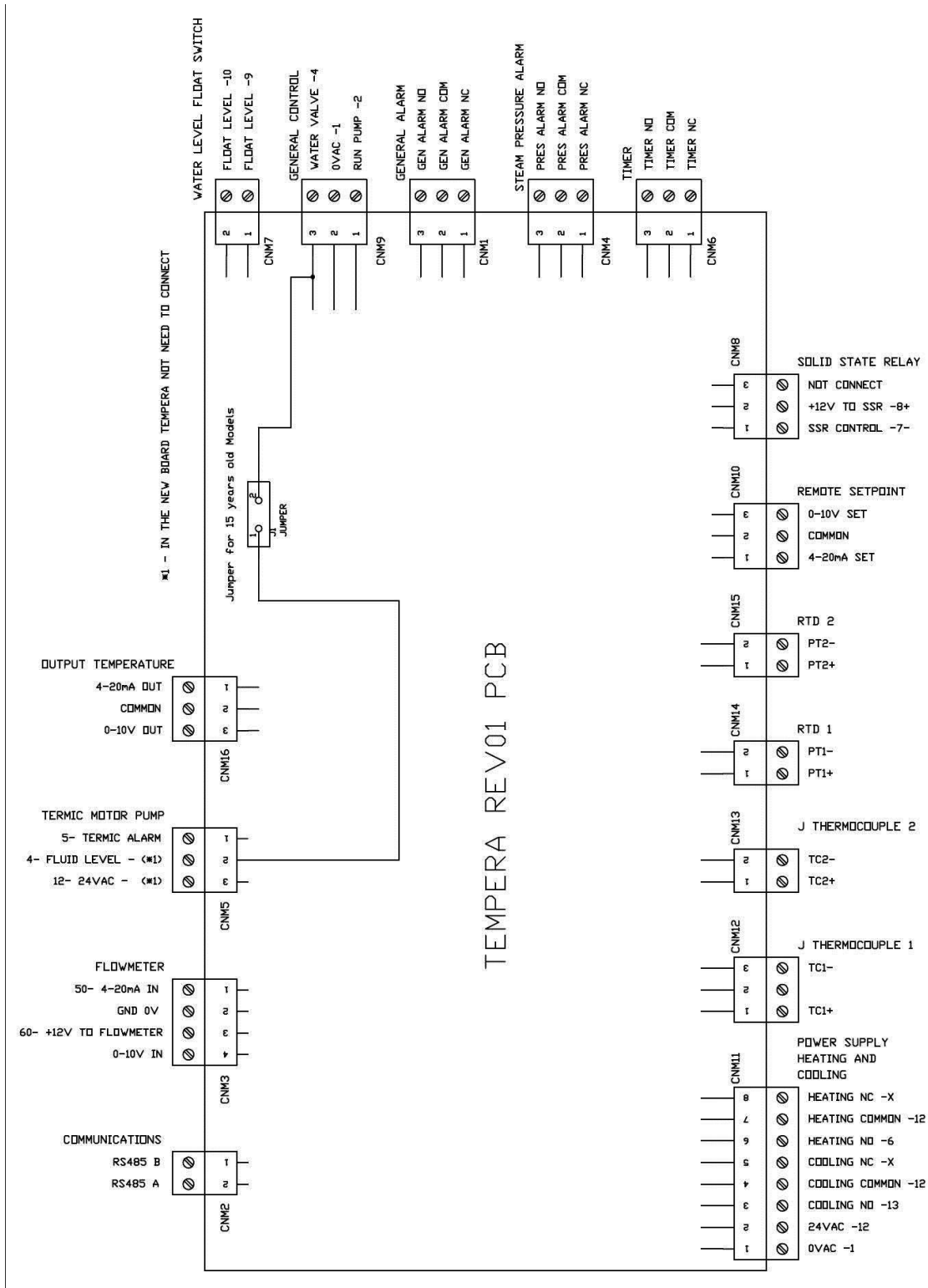

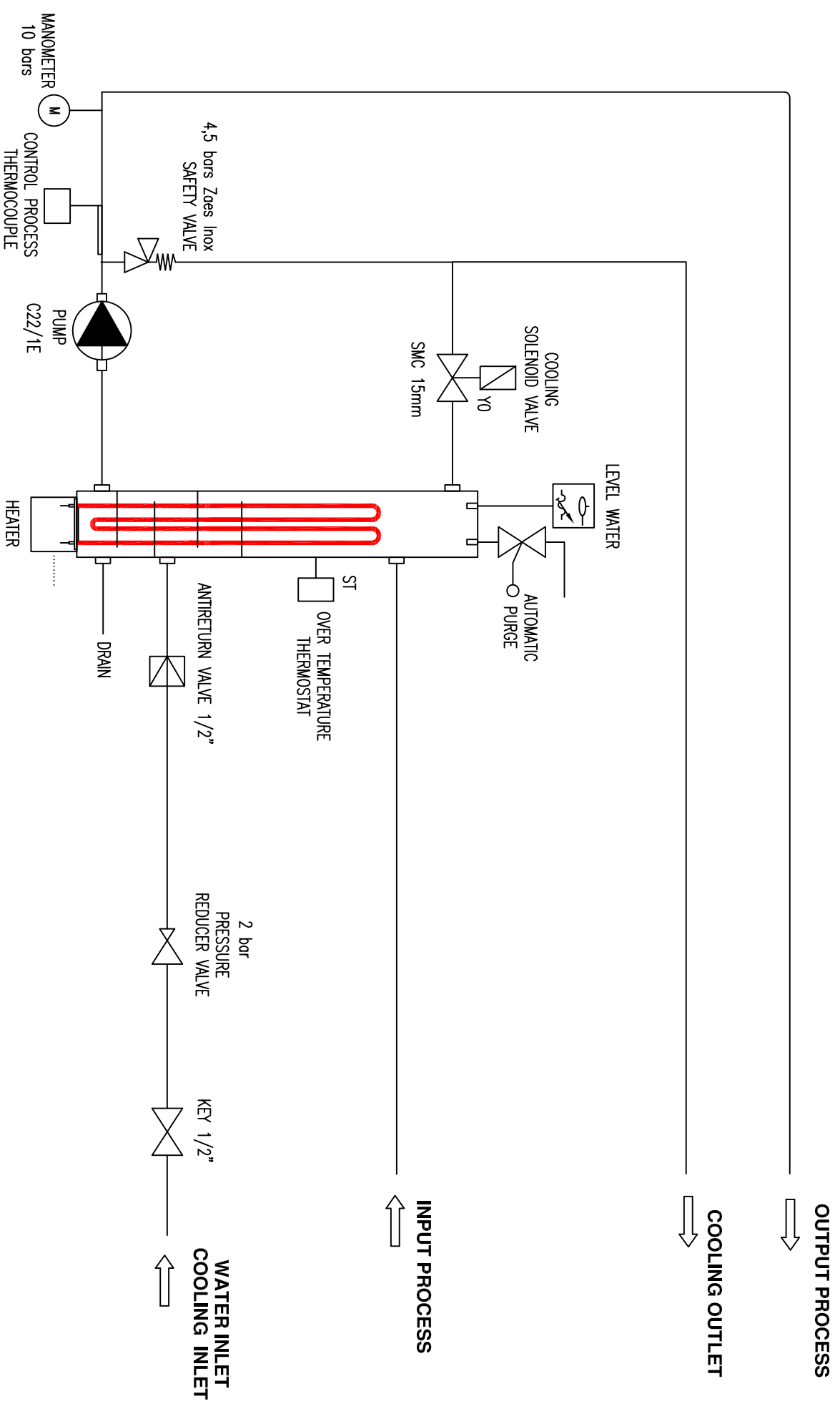

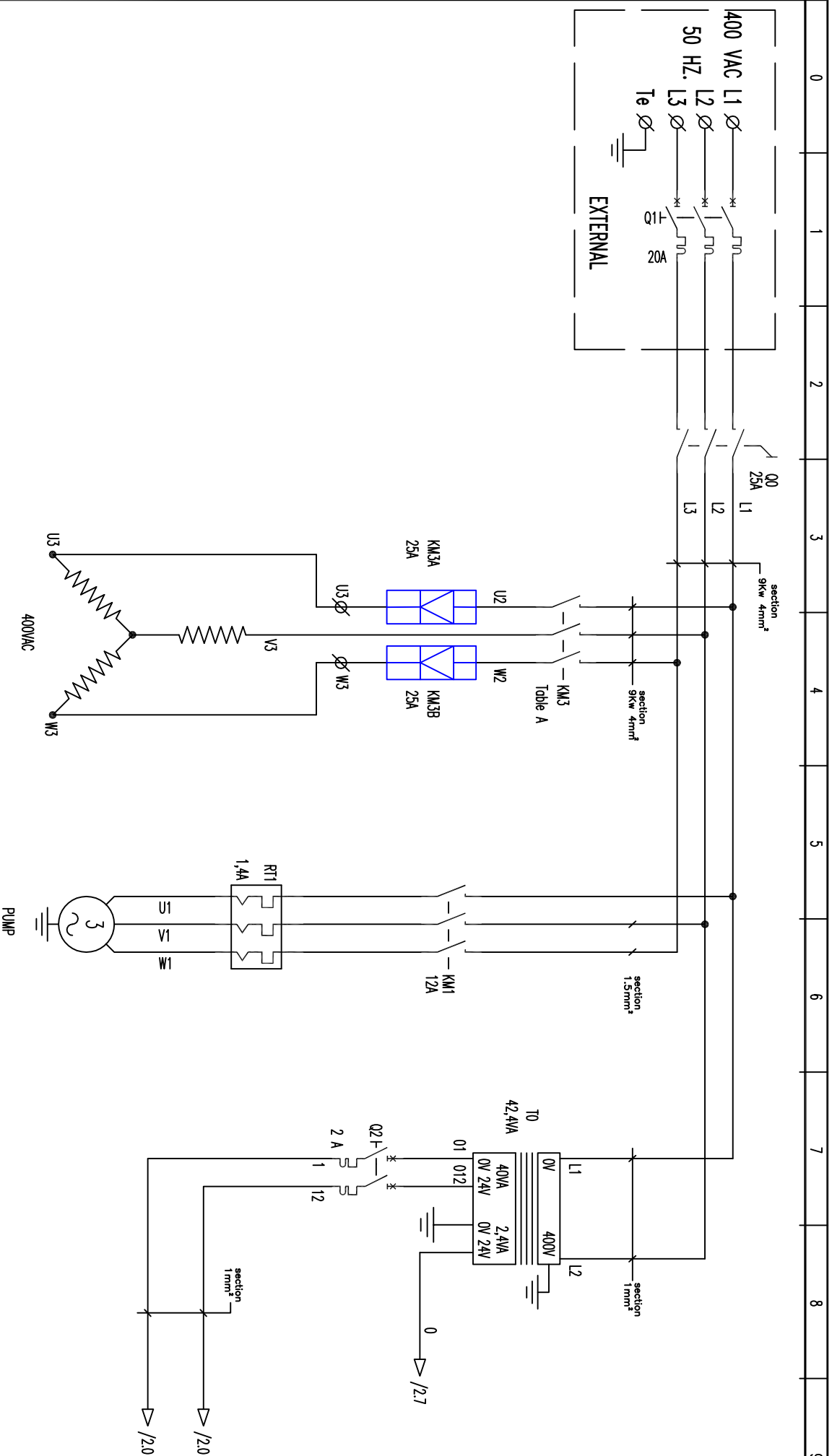

0	1	2	3	4	5	6	7	8	9
---	---	---	---	---	---	---	---	---	---

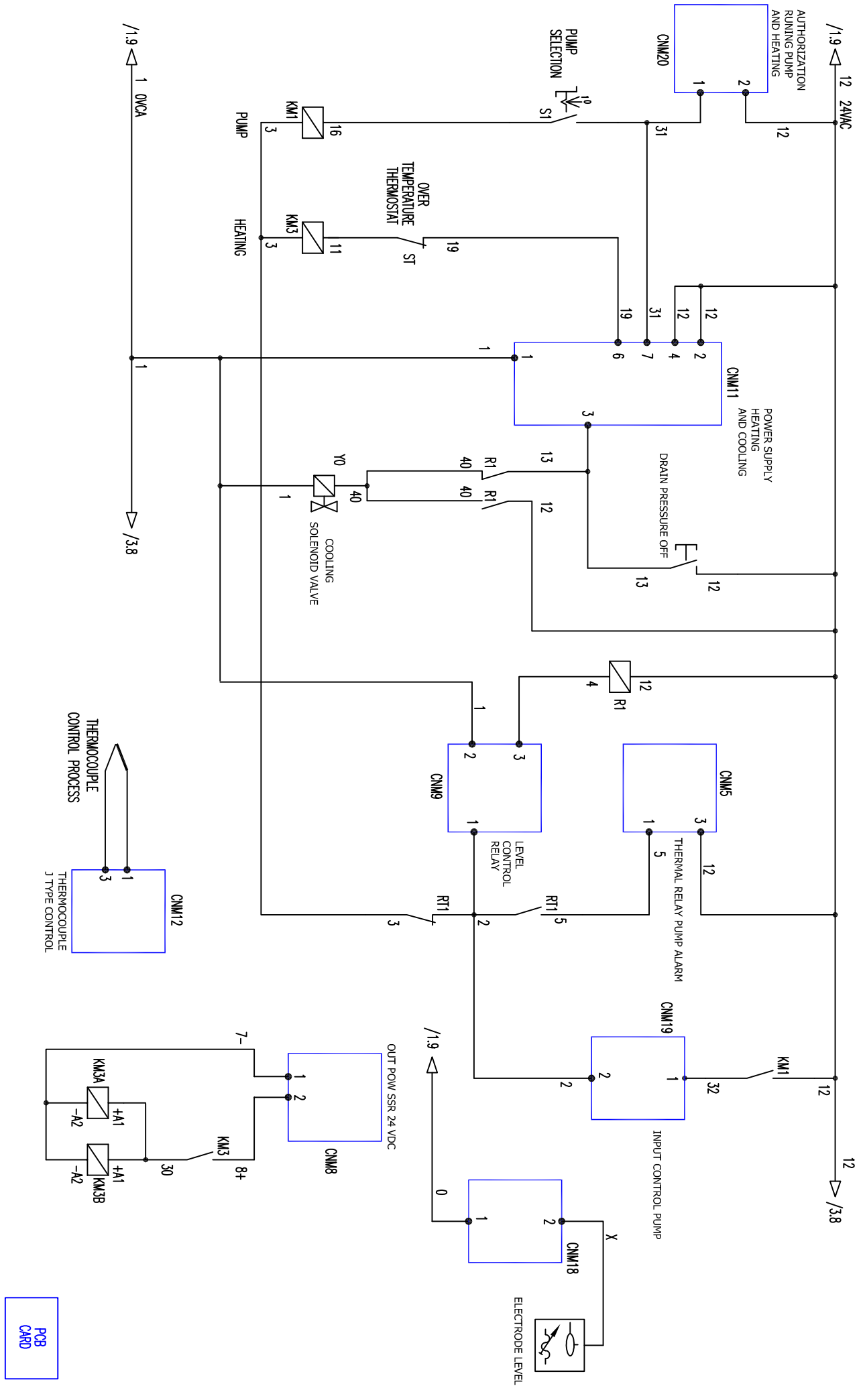

PCB CARD

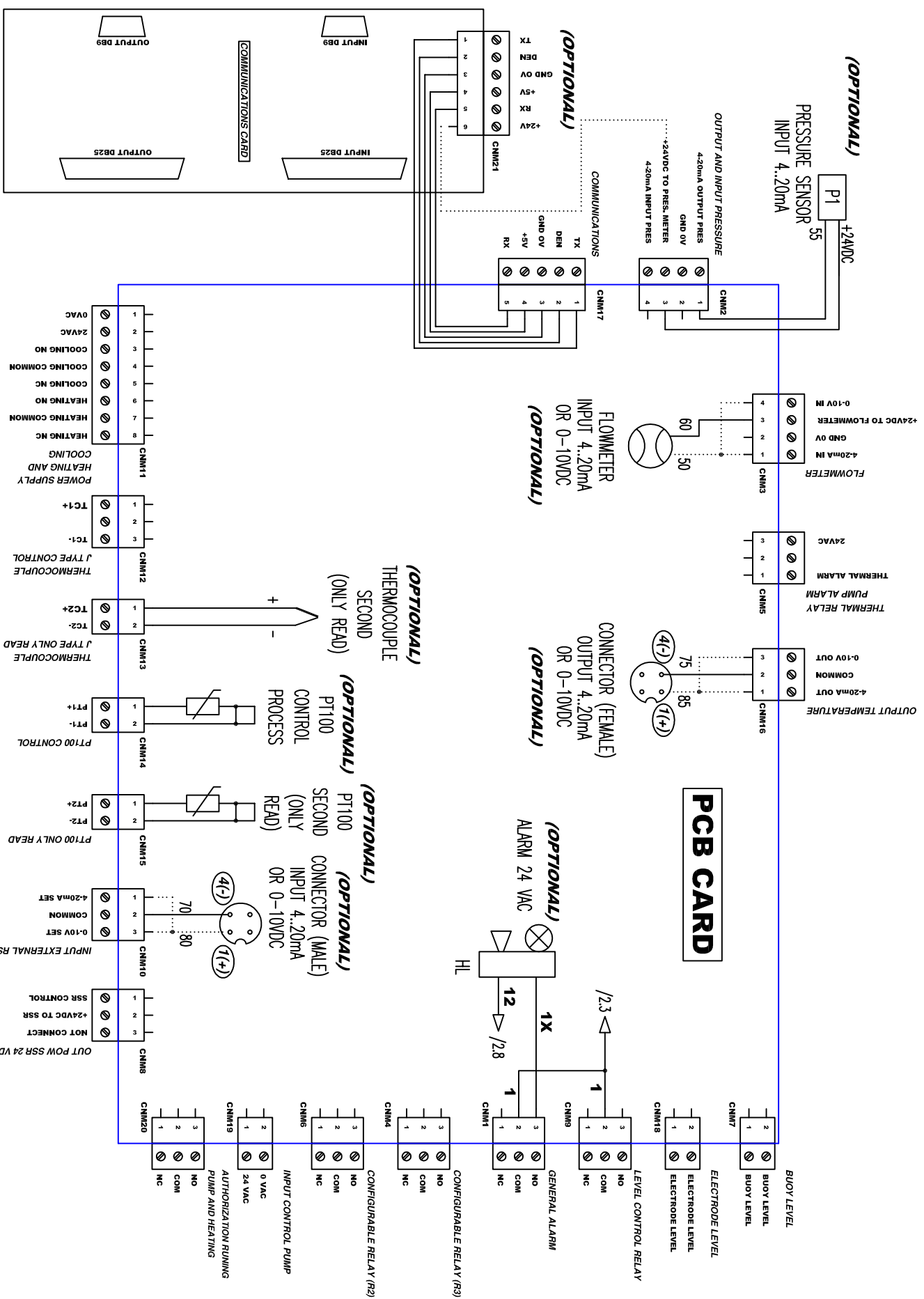

DATE

08/03/2017

MODEL:

TCU-120
PCB Card + Options

PAGE:

Index

1. Overview front.
2. Information on the screen.
3. Viewing alarms and their performances in the process.
4. Operation of the keyboard.
5. LEDs process information and start pump.
6. Sets control programming.
7. Leak monitoring process.
8. Control relays configurable to user and application examples.
9. Description card connectors.

1. Overview front

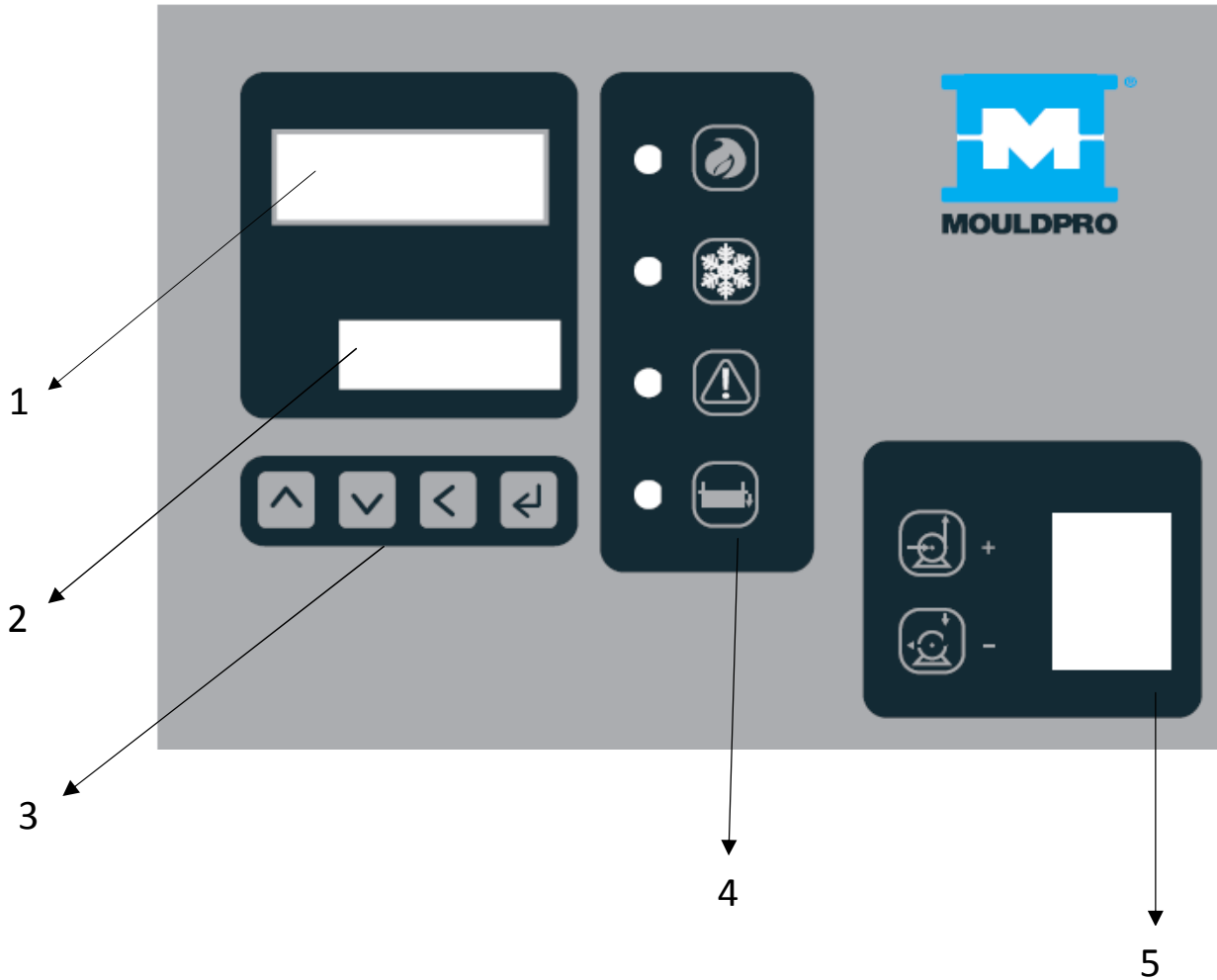

- 1- Outlet temperature to process.
- 2- Set point
- 3- Function keys.
- 4- LED's process information.
- 5- Switch pump and heating operation.

2. Information on the screen

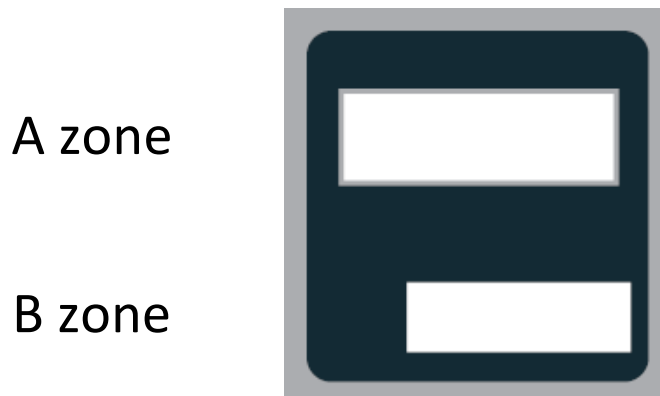

A zone

B zone

A Outlet temperature to process.

B Set point

More information pcb card can show us in the screen

By default, leak monitoring is activated, showing  in B area.
“ L ” stop flashing when leak monitoring enters surveillance.

Depending on TCU model and activated options, pressing the key



Will be shown on the display in B area.

Pressure pump outlet



Return pressure process

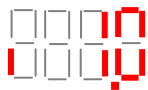

Process flow in return



Return temperature



Return process thermocouple open



Other messages can be seen in A-B area pressing  if TCU unit has activated configurable relays (R2 or R3).

Configured relays

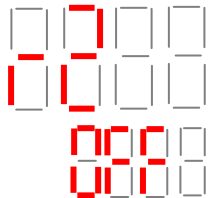

Activated relays

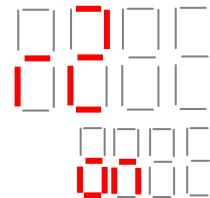

If REMOTE SET POINT function is activated by a signal 4..20mA or external 0..10Vdc, in B area will show in cycles of 3 seconds

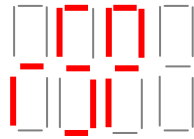

If TCU unit is working through RS485 or 0..20mA communications in B area will show in cycles of 3 seconds



If we had more machines linked, second TCU unit will show in cycles of 3 seconds

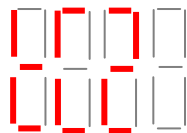

3. Alarm display

In A-B zone will show all alarm situations, which can be:

Maximum process start time. User adjustable. Restarts TCU unit

00:00
00:00

Minimum return flow alarm. User adjustable. Disables heating.

0000
0000

Connection between flow meter and PCB card is open.
Disables heating.

0000
0000

Connection between process pressure transducer and PCB card is open.

0100
0100

Connection between return process pressure transducer and PCB card is open

0000
0000

Connection between Remote set point signal 4..20mA o 0..10Vdc is open . Holds last Setpoint value

No connection between PCB card and RS485 o 0..20mA.
Holds last Setpoint value

Thermocouple open.

Disable the heating and pump. Restarts activation leak monitoring

Overload pump protection.

Disable heating and pump. Restarts activation leak monitoring

Maximum drive pump. User adjustable.

Disable heating and pump. Restarts activation leak monitoring

Maximum temperature difference between process and setpoint.
User adjustable

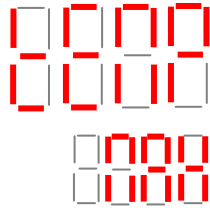

Maximum and minimum temperature difference between process and setpoint. User adjustable.

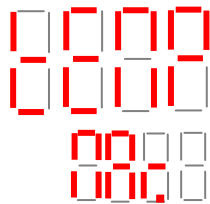

Possible water leaking problem in the process.
Disable heating and pump. Restarts TCU unit.

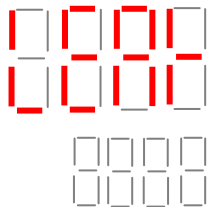

Low water level for more than 10 seconds continuously in the TCU unit tank. Disable heating and pump. Restarts TCU unit.

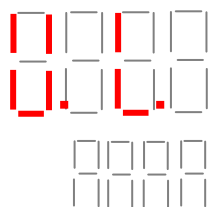

Press  to validate the alarm. If the alarm condition persist message will appear in the display and will act again.

4. Keyboard operation.

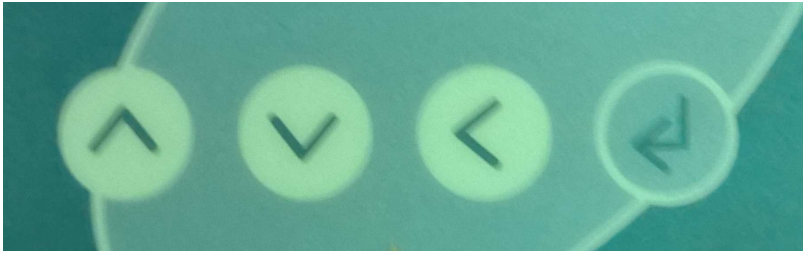

To change set point press . Digit on the right side will flash, to change the value press or .

In order to change the digit press .

Press to save changes.

To enter the programming SETS, hold the key and then hold simultaneously the key .

Then in A zone of the display will show ST-0 :

To go to the desired ST press .

Once in the desired ST, press We visualize the first parameter in the ST.

To change the parameter press , to change the parameter value press the keys or to change the digit press .

To save changes press .

5. LEDs process information and start pump.

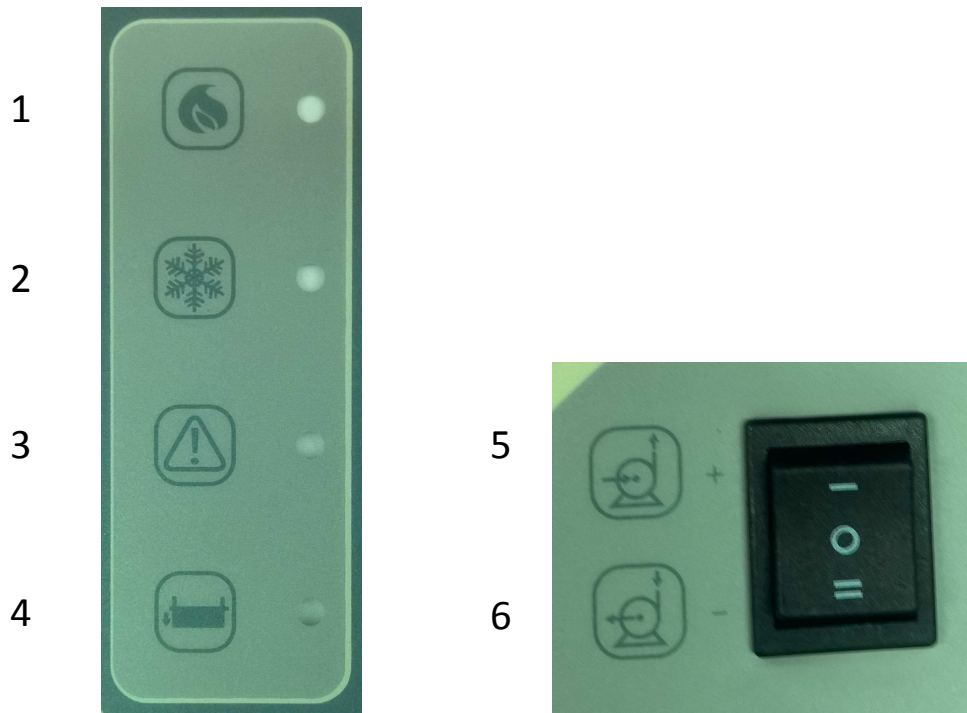

1 Heating led

2 Cooling led.

3 Overload TCU pump led.

4 Low fluid level led.

5 Pump pressure function.

6 Pump depression function.

IMPORTANT:

Check pump rotation, it must be clockwise.

6. Programming Sets.

To view and modify programming sets.

(See page 10).

Depending on the type of PCB card, and incorporated options into the TCU unit, there are parameters that are not activated.

ST-0



Proportional band of the PID control. Self-adjusting.

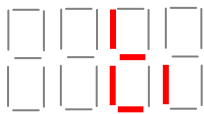

Integral time of PID control. Self-adjusting.

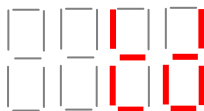

Derivative time process. Self-adjusting.

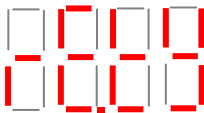

Relay type heating. Not modifiable by the user.

SSR- Enables heating through solid state relays.

Cont- Activates the heating through the contactor KM3.



Heating ramp. Do not change without consulting the manufacturer.

This parameter is activated when entering the PID control.

In cycles 10 seconds, if the temperature has not exceeded this value in degrees, will activate again heating. If on the contrary it has exceeded, heating is not activated until the next cycle, which will return him to look.

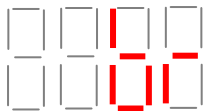

Heating Brake. Do not change without consulting the manufacturer.

Heating gives 100% less the value of "**br**". When it comes down to this value, start the PID control.

In pressurized water machines when set point is more than 105 °, PID control began at 95 °.

ST-1



Cooling proportional value. Self-adjusting.

Do not change without consulting the manufacturer.

It is no unit of measure (proportional value that multiplies the time the cooling solenoid valve is connected. This time is given by the PID).



Cooling Brake . Do not change without consulting the manufacturer.

Cooling gives 100% to the working temperature plus "**CL.br**" value. When it comes down to this value, start the PID control.

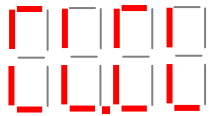

Cooling ramp. Do not change without consulting the manufacturer.

This parameter is activated when entering the PID control.

In cycles of 8 seconds, if the temperature has not exceeded this value, it will activate again cooling. If on the contrary it has exceeded, cooling is not activated until the next cycle, which will return him to look.

ST-2

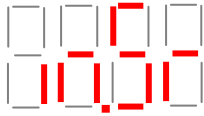

Type of thermocouple. Do not change without consulting the manufacturer.

We choose if the thermocouple is J type (TC 1) or Pt1000 (Pt1).



Flow meter activation.

Activate or not the flowmeter. On-OFF.



Flowmeter signal. Do not change without consulting the manufacturer.

Flow meter signal is done by 4..20mA (SrC.A) or 0..10Vdc (SrC.u).

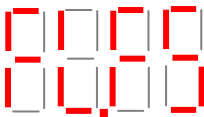

Full scale of the flow meter. Do not change without consulting the manufacturer.

Maximum value in l/min. According flow meter specifications.

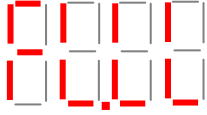

Flow meter initial scale. Do not change without consulting the manufacturer.

Minimum value in l/min. According flow meter specifications.



Alarm flow meter. User adjustable.

Minimum value in l/min flow meter to activate the alarm.

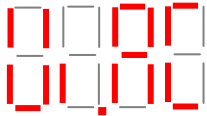

Activation return sensor.

Activate or not in the display the return / external thermocouple

On-OFF.

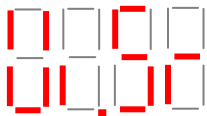

Type of return / external thermocouple

We choose if the thermocouple is J type (TC 1) or Pt1000 (Pt1).

ST-3



Temperature type alarm.

rEL: relative on the set point. Just above value as "SP.AL" parameter.

GAP: on the set point above and below value as "SP.AL" parameter. Activatable when TCU unit reached the set point.

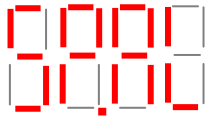

Overtemperature alarm.

It is the alarm value in degrees will act respect to the set point.

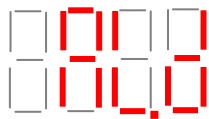

Alarm relay action.

dir: Connector CNM1 activates the signal alarm by NO contact .

rEu: Connector CNM1 activates the signal alarm by NC contact.

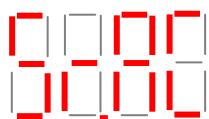

Enabling remote set point.

Activate or not the remote set point On-OFF.



Remote set point.

Remote set point signal "SrC.A" 4..20mA or "SrC.u" 0..10Vdc



Full scale remote set point.

It is the value in degrees of the maximum temperature of the remote set point.

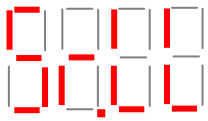

Minimum scale remote set point.

It is the value in degrees of the minimum temperature of the remote set point.

IMPORTANT: If TCU unit has selected the entry "Sr.SC" as "SrC.u" (input 0..10Vdc) the minimum range may not be the value in degrees 0Vdc.

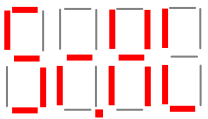

Maximum value of remote set point.

Maximum value in degrees TCU unit can be set by remote set point.

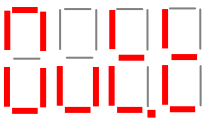

Outlet process temperature.

Type of Input /Output temperature, is done through mA "out.Â" (4-20 mA) or volts "Out.u" (0-10 Vdc). These values will always be proportional between the values in degrees that have been made to the parameters of St-4 "SP.LL" (4 mA-0 Vdc) and "SP.HL" (20 mA-10 Vdc).

ST-4

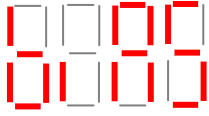

Offset temperature correction.

It used to correct the reading of temperature for above and below respect to an external measurement probe.

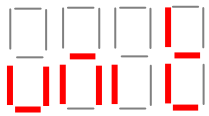

Unit temperature.

We choose if we want the temperature in degrees Celsius "° C" or degrees Fahrenheit "F".

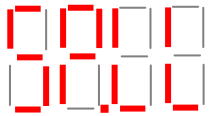

Minimum set point setting.

It is the minimum temperature machine can be set.

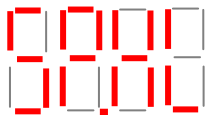

Maximum set point setting.

It is the maximum temperature machine can be set.

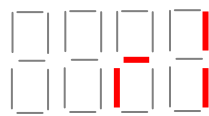

Relay 1 configuration.

Not configurable by the user.

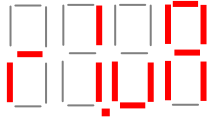

Value in degrees, bars, liters/minute, depending on the configuration of the previous parameter "r1".

Not configurable by the user.

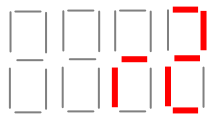

Relay 2 configuration

Configurable as:

OFF: Disabled

tP1: Output temperature to the process.

tP2: Return temperature process.

P1: Pump pressure.

P2: Return process pressure.

FM1: Return process flow.

AL: General alarm.

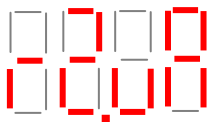

Value in degrees, bars, liters/minute, depending on the configuration of the previous parameter "r2".

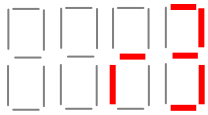

Relay 3 configuration

Configurable as:

OFF: Disabled

tP1: Output temperature to the process.

tP2: Return temperature process.

P1: Pump pressure.

P2: Return process pressure.

FM1: Return process flow.

AL: General alarm.

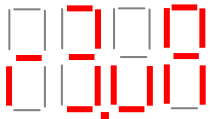

Value in degrees, bars, liters/minute, depending on the configuration of the previous parameter "r3".

ST-5

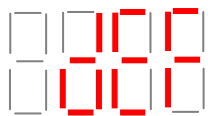

By entering the value 1562, let us enter the St-0 and St-1.

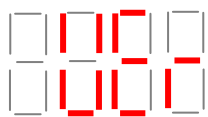

Software version.

ST-6

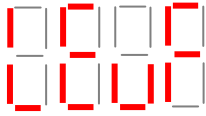

Value to 0, the time to enter the programming SETS is 5 seconds.
With value 1, the time to enter the programming SETS is 15 seconds.

ST-7

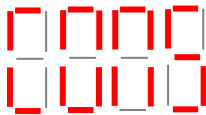

Enabling communications.

Activate or communications On-OFF.

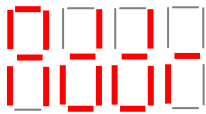

Address assigned to the TCU unit.

The first TCU unit will be address 1, if more linked machines the following would be address 2 and so on.

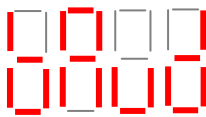

Transmission speed.

"0" (2400bauds), "1" (4800 baud) and "2" (9600 baud).



Parity bit.

"0" (no parity), "1" (non parity) i "2" (even parity).

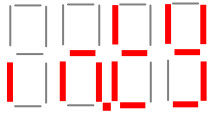

Interface type. "420" (4-20mA) or "485" (RS485).

When you select "485", the following parameter dEn not appear.

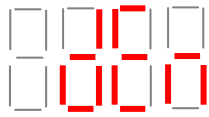

Data enable.

When the interface type is 420 and only have one TCU linked to the MASTER machine, **dEn** parameter value is "1" (close circuit); if more than one TCU linked all will have **dEn** value "0" less the last one it will have **dEn** value "1".

ST-8

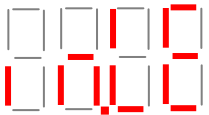

Fluid level setting.

Not modifiable by the user.

Select if the level control is done by electrode "ELEC" or buoy "BuOY".

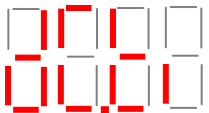

Extra time level detection.

Water filling valve retard disconnection time. Value in seconds.

NO CHANGE WITHOUT CONSULT THE MANUFACTURER

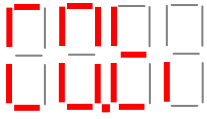

Extra time no level detection.

Water filling valve retard connection time. Value in seconds.

NO CHANGE WITHOUT CONSULT THE MANUFACTURER

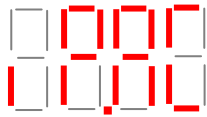

Display activation drive pump.

Activate or not the on-off display.

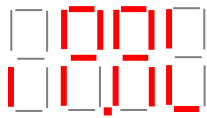

Alarm output drive pump.

Value in bars.

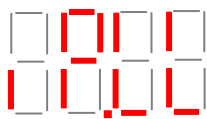

Initial scale transducer drive pump.

Value in bars.

NO CHANGE WITHOUT CONSULT THE MANUFACTURER

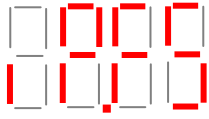

Full escale transducer drive pump.

Value in bars.

NO CHANGE WITHOUT CONSULT THE MANUFACTURER

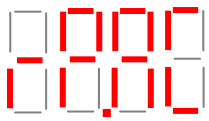

Display Activation return pressure.

Activate or not the display. On-off

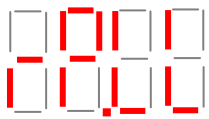

Initial scale return transducer drive pump.

Value in bars.

NO CHANGE WITHOUT CONSULT THE MANUFACTURER

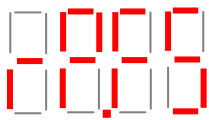

Full escale return transducer drive pump.

Value in bars.

NO CHANGE WITHOUT CONSULT THE MANUFACTURER

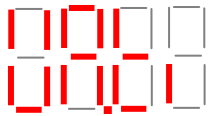

Maximum process start time.

Value in minutes.

NO CHANGE WITHOUT CONSULT THE MANUFACTURER

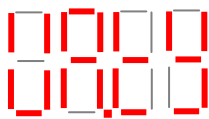

Contact NO or NC input level.

Not modifiable by the user.

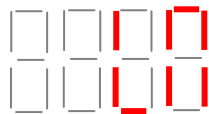

Leak monitoring.

Activate or not the monitoring control. On-OFF.

See page 26.

7. Leak monitoring.

Default leak monitoring is enabled, and can be disabled by LM parameter in the St-8 menu.

The process works as follows:

Water / oil TCU units:

When process start , letter L (zone B) will flash. When the TCU pump is more than 2 minutes running in continuous (this will mean that there is no demand for water/oil in the process), the letter L will stop flashing. From this moment, leak monitoring is enabled.

Leak detection:

Once monitoring is enabled (in water process) if we demand for water more than once in an hour, or repetitive demands on for 4 consecutive hours, in zone A message is displayed  will activate the audible alarm by turning off the pump and heating temperature control unit.

Once the user has disconnected the pump switch and confirmed the alarm by pressing . Fix the leakage problem, fixed the leakage connect again the pump switch TCU unit will restart automatically.

Another leak detection (designed for oil TCU units) is:

if the process is more than 10 seconds in oil demand (this may be due to a loss level in the TCU unit) because filling is manual and not incorporating automatic filling in area A the message displayed will be  will activate the audible alarm by turning off the pump and heating temperature control unit.

Once the user has disconnected the pump switch and confirmed the alarm by pressing . Fix the leakage problem, fixed the leakage connect again the pump switch TCU unit will restart automatically.

Deactivation leak monitoring :

If the user disables leak monitoring, the letter L (zone B) will not appear.

The alarm  never act.

Alarm  can act, whether the process is water or oil but, pump must be running in continuous for 2 minutes.

8. Configurable relays.

Depending on TCU model, can add up to 2 configurable relays for user process automation. Making the TCU unit in a process control system.

These switched relays with potential free contacts (support up to 6A), listed as **r2** and **r3** in the St-4 menu, can be configured to work with the control signals incorporating the TCU unit (which are activated by exceeding the value programmed), are:

- a) Pump pressure.
- b) Return pressure.
- c) Outlet process temperature.
- d) Inlet process temperature.
- e) Flow lit/min in return process.
- f) General alarm.

Examples:

The user needs to know when the mold temperature has reached the value he wants to start the process.

Through external thermocouple located in the mold provided by the user to the TCU unit, will control the temperature using the r3 relay.

When the temperature exceeds the set value, the relay r3 provide the user a signal it allow to start the application.

If the mold had no thermocouple could be done as follows:

We will control the temperature of the return process by the thermocouple at the temperature control unit with relay r3.

Check externally (contact thermocouple, laser gun) when the mold is at optimum operating temperature, and display on the screen which is the return temperature at that time. In this way we could set the value in the relay r3, which will provide the user for future occasions, the signal to start its application in this mold.

Prevent overpressure in inlet mold.

This application could be interesting when our mold has parts that can not withstand high pressures and need early detection to prevent possible damage.

We will control the pump discharge pressure to the entrance of the user process by r2 with a value (example 3 bar). If this pressure is higher than the preset in r2, this will provide signal to the user, which could perform a bypass between inlet and outlet of the mold and an alarm.

9. Description PCB card connectors.

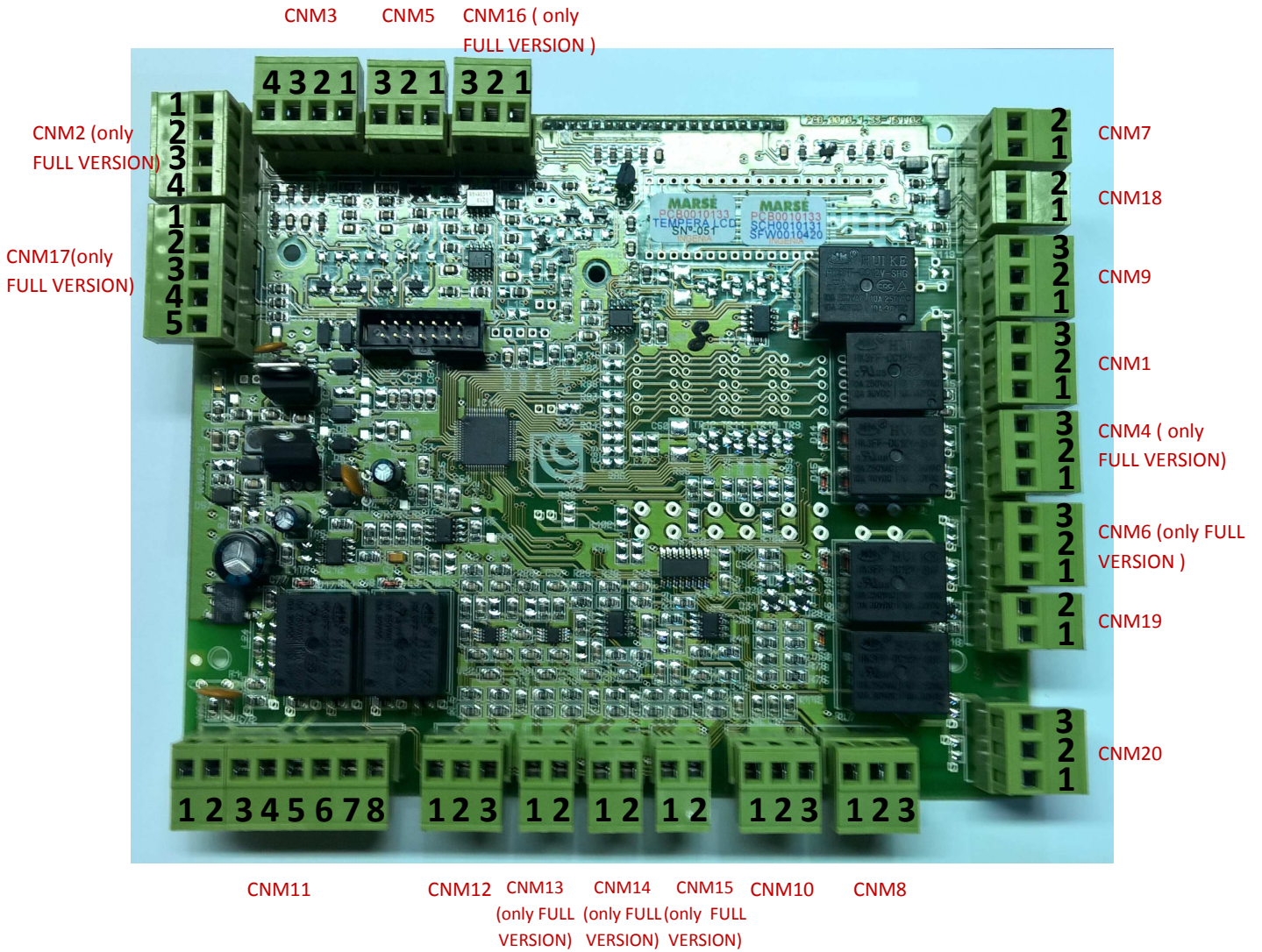

- CNM1:** General alarm relay.
- CNM2:** Inputs pressure transducers.
(only FULL version PCB card)
- CNM3:** Input flow meter
- CNM4:** Configurable relay (R3).
(only FULL version PCB card)
- CNM5:** Thermal relay pump alarm.
- CNM6:** Configurable relay (R2).
(only FULL version PCB card)
- CNM7:** Input level detection (magnetic buoy).
- CNM8:** Output power SSR 24 Vdc.
- CNM9:** Level control relay.
- CNM10:** Input external RSP.
- CNM11:** Input 24 Vac power / control of heating and cooling.
- CNM12:** Input process thermocouple J type control.
- CNM13:** Input return/external thermocouple J type only read.
(only FULL version PCB card)
- CNM14:** Input process thermocouple PT1000 type control.
(only FULL version PCB card)
- CNM15:** Input return/external thermocouple PT1000 type only read.
(only FULL version PCB card)
- CNM16:** Analog output process temperature.
(only FULL version PCB card)
- CNM17:** Inlet / outlet communications.
(only FULL version PCB card)
- CNM18:** Input water level detection (electrode).
- CNM19:** Input control pump.
- CNM20:** Authorization running pump and heating.